

20. FATC (FULL AUTO TEMPERATURE CONTROL) CIRCUIT

1) BLOWER MOTOR, MODE MOTOR, INTAKE MOTOR CIRCUIT

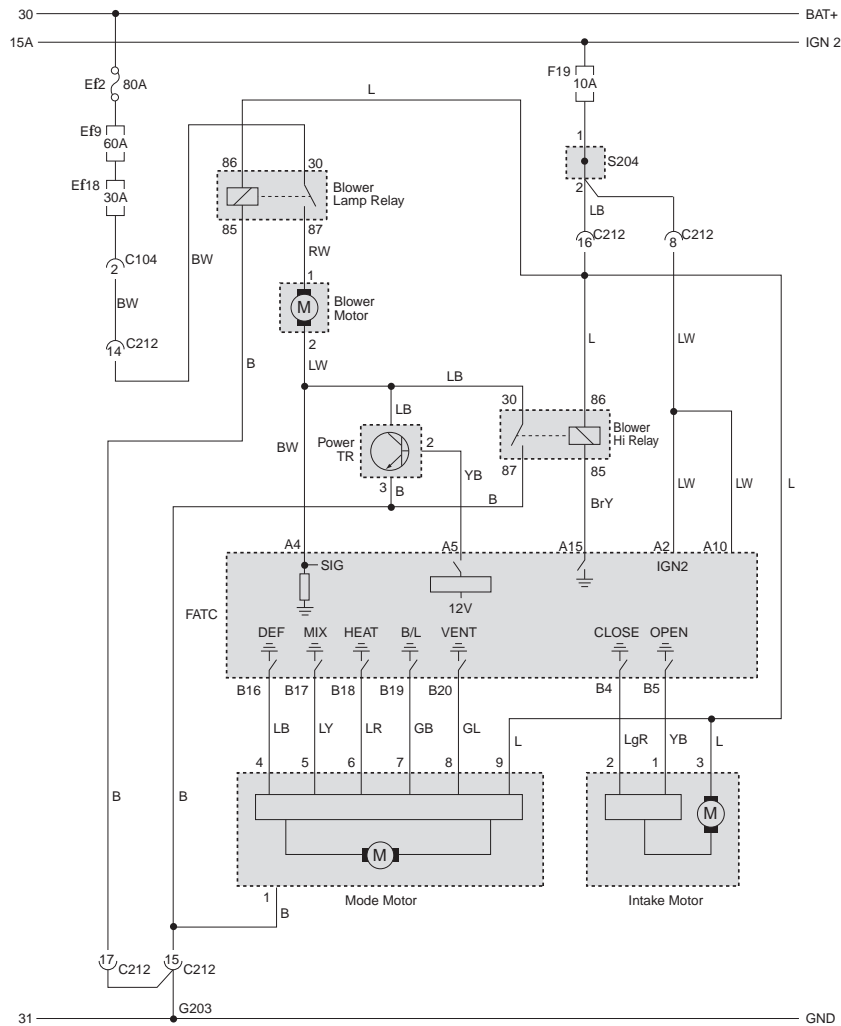

a. CONNECTOR INFORMATION

CONNECTOR(NUMBER)	CONNECTING. WIRING HARNESS	CONNECTOR POSITION
C104 (15Pin, Black)	Enginex - Main	Under The Engine Room Fuse Block
C212 (17Pin, White)	Main - Air Con	Behind The Glove Box
S204 (Black)	Main	Upper Right The Audio
G203	Main	Upper The ECM

b. CONNECTOR IDENTIFICATION SYMBOL & PIN NUMBER POSITION

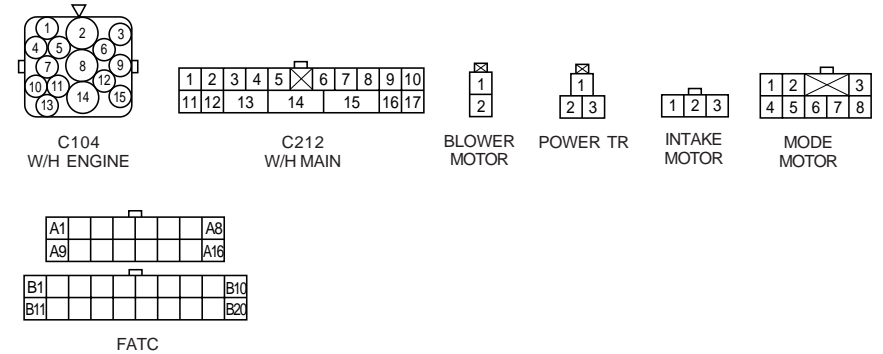

c. POSITION OF CONNECTORS AND GROUNDS

- W/H A/C

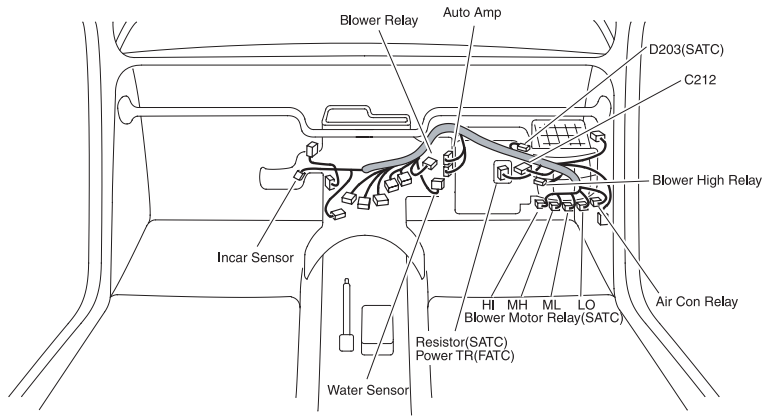

d. SPLICE PACK

S204 (BLACK)

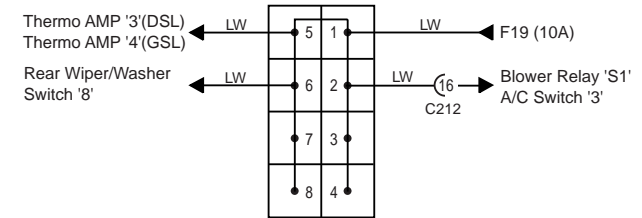

- W/H MAIN (I/P)

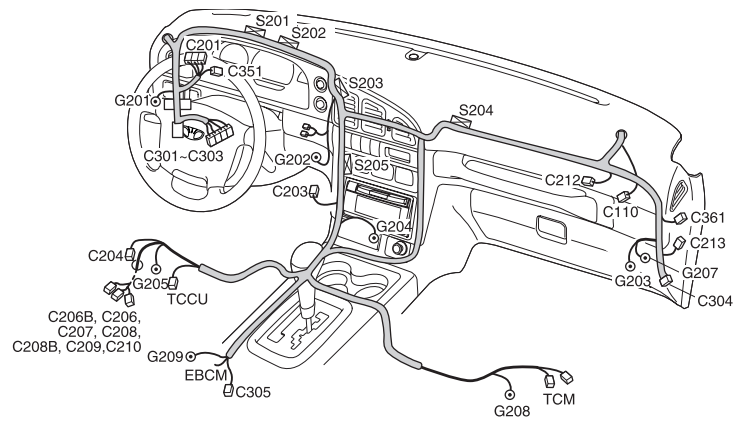

2) SENSOR (AMBIENT, SUN, WATER), AIR MIX DOOR MOTOR CIRCUIT

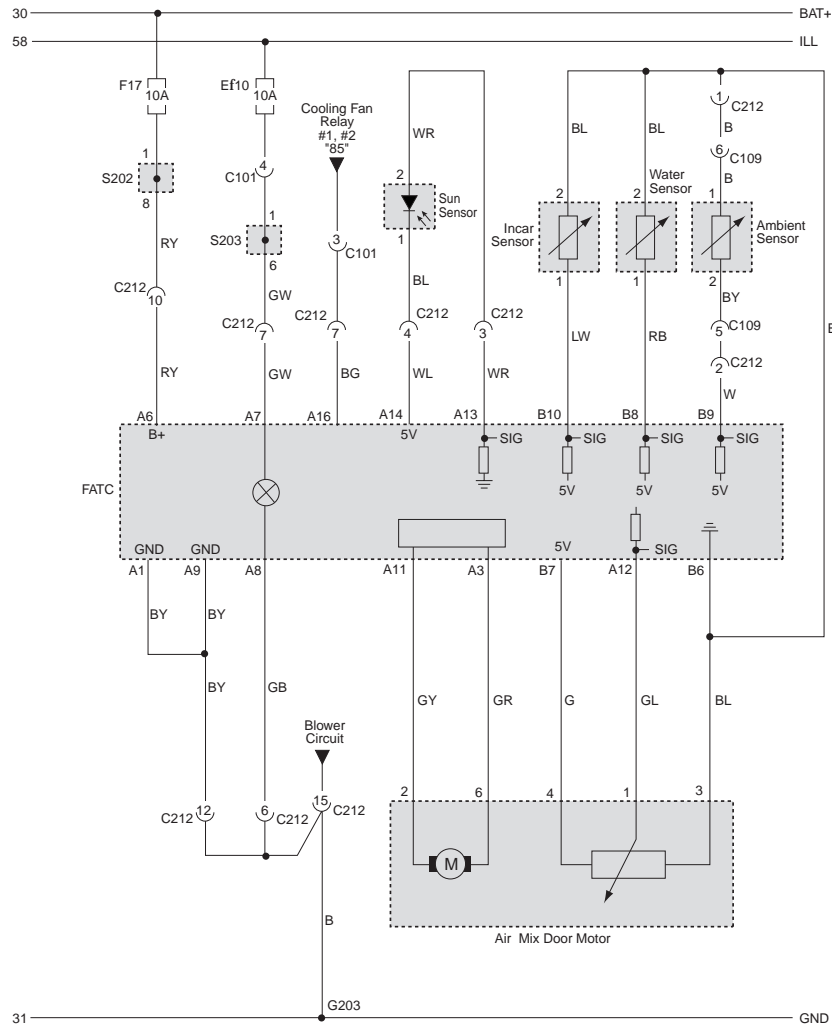

a. CONNECTOR INFORMATION

CONNECTOR(NUMBER)	CONNECTING. WIRING HARNESS	CONNECTOR POSITION
C101 (21Pin, Colorless)	Main - Engine	Inside The Engine Room Fuse Block
C109 (16Pin, Black)	Engine - Main	Under The Coolant Reservoir Tank
C212 (17Pin, White)	Main - Air Con	Behind The Glove Box
S202 (Gray)	Main	Behind The Cluster
S203 (Gray)	Main	Upper Right The Audio
G203	Main	Upper The ECM

b. CONNECTOR IDENTIFICATION SYMBOL & PIN NUMBER POSITION

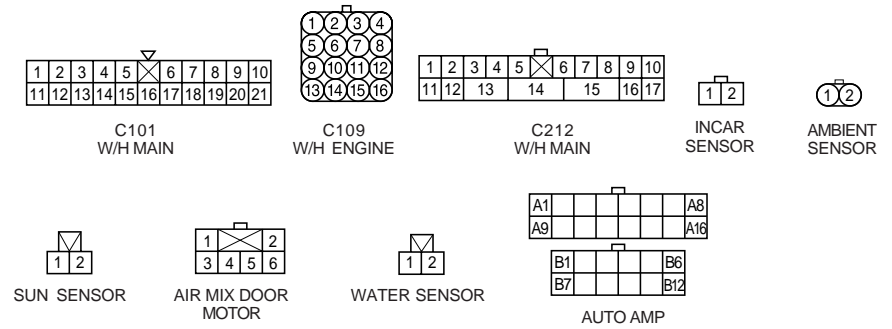

c. POSITION OF CONNECTORS AND GROUNDS

- W/H A/C

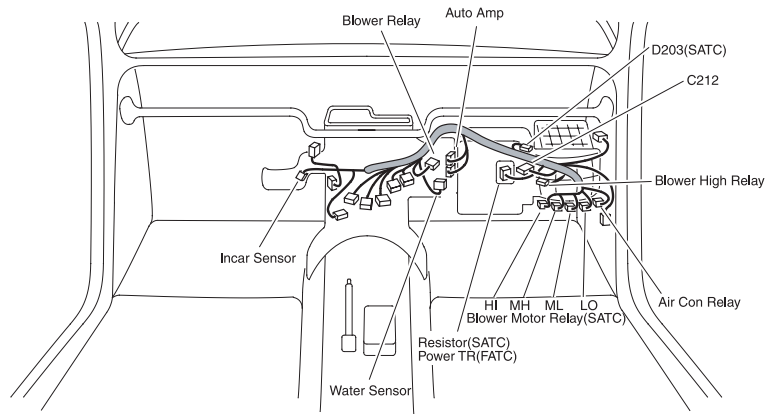

- W/H MAIN (I/P)

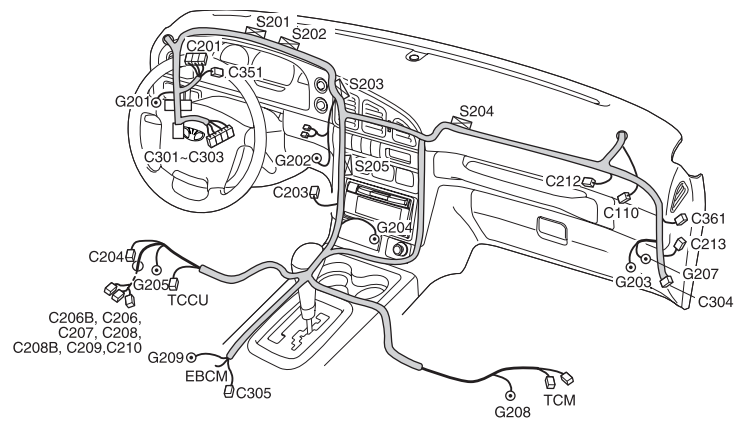

d. SPLICE PACK

S202 (GRAY)

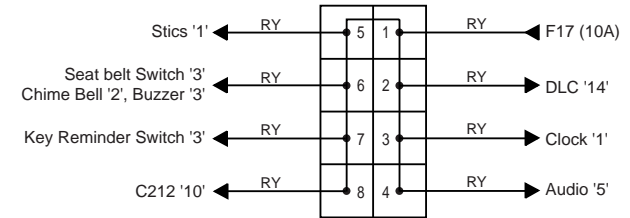

S203 (GRAY)

